

DUALTRON

POP

*En raison de la **nature** du produit, les retours en boîte ouverte **ne** sont pas acceptés.

MANUAL D'UTILISATION

Veillez lire le manuel d'utilisation en entier avant d'opérer.

Ne laissez pas les autres utilisateurs utiliser la trottinette sans avoir lu le manuel.

* Cette trottinette est très puissante, vous pourriez être en danger si vous ne l'utilisez pas conformément aux lignes directrices énoncées dans ce manuel.

NOTICE ORIGINALE

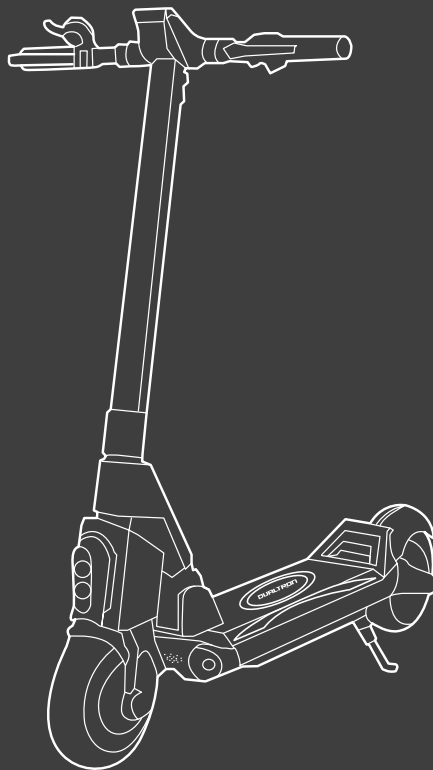



Scanner le QR code pour télécharger la dernière version du manuel d'utilisation et obtenir les dernières mises à jour et consignes de sécurité

DUALTRON

Le rêve de la technologie électrique

Les images figurées dans ce manuel sont non contractuelles

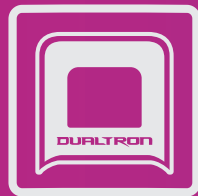

MINIMOTORS



Specifications

	Item	Parameter
Product	Model	Dualtron pop (Single motor) Dualtron pop (Dual motor)
Battery	Battery Capacity	52V14Ah CN / 52V20Ah CN / 52V25Ah LG
	Range	30km / 45km / 60km
	Charging Ambient Temperature	0 to 40°C (Battery temperature exceeds 55°C, BMS start protection program.)
	Battery Management System	Over-heating, short circuit, over-current, over-discharge and over-charge protection
Rider	Max. load	120kg
	Recommended Age	14–60 years old
Display	Type	EY2 LCD Bluetooth Display (Ability to connect to DUALTRON APP)
Motor	Motor Type	BLDC Hub Motor
	Nominal Power	450W 450W*2
Machine	Net Weight	29.6 kg (single motor) 32.5 kg (dual motor)
	Max. Slope	Around 27% (15° Single-wheel drive) Around 37% (20° Two-wheel drive)
	Drive System	Single motor drive Dual motor drive
	Speed	25km/h
	Length × Width × Height	1220x660x1220mm
	Folded: Length × Width × Height	1230x260x450mm
	Wheelbase	Approx. 970mm
	Ground Clearance	Approx. 100mm
	Traversable Terrain	Asphalt/flat pavement; obstacles < 5 cm; gaps < 5 cm
	Operating Temperature	-5 to 45°C
	Storage Temperature	-20 to 50°C



Specifications

Brake	Type	Dual drum brake
	Electric Brake	ABS&EBS (Indicating the battery temperature exceeds 55°C,BMS start protection program,ABS/EBS fails.)
Charger	Input Voltage	100-120V/200-240V~
	Max. Output Voltage	58.1V2A
Tire	Type	9 inch tube tire
	Tire Pressure	50 psi
	Material	Rubber
Suspension	Type	Front air spring shock absorber & rear spring shock absorber

*Disclaimer: this is not a legal opinion or legal advice. The information provided herein (including in the App) is for your convenience and information purpose only. It is not intended to cover every piece of law and/or regulation that may be applicable to this product. DUALTRON explicitly hereby disclaims any and all warranty and/or representation, express or implied, related to completeness, accuracy, up-to-date of such information. DUALTRON reserves the right but not obligation to correct, implement and/or update the information. You shall use the information at your own risk. It is your sole responsibility to learn and understand any and all the law and/or regulation, requirements, prohibition, restriction and/or limitation imposed by either law, government authority, court, private party or the others that may apply to your use of this product.

*Theoretical Range: tested while riding with a full battery, 75 kg load, 25°C, at the speed of 25 km/h on average on pavement.

*Typical Range: tested while riding with a full battery, 75 kg load, 25°C, at the speed of 50 km/h on average on pavement. (Some of the factors that affect range include speed, number of starts and stops, ambient temperature, etc.)

*Max.Speed: tested while riding with a full battery,75kg load,25°C,straight road on flat road with no wind. (Some environmental factors can affect max speed,uneven roads, crooked roads, temperature, wind, etc.)



Packing List

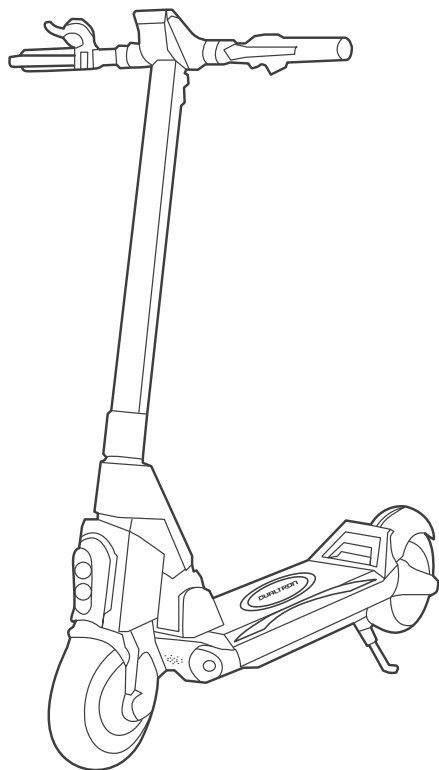

Accessories



Main battery charger x1

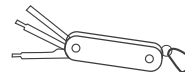

Multitool x 1



Manual



Assembly

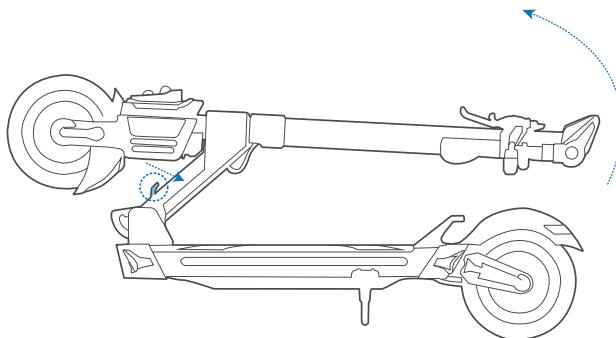

① Push the folding handle inward while raising the steering tube with the other hand.

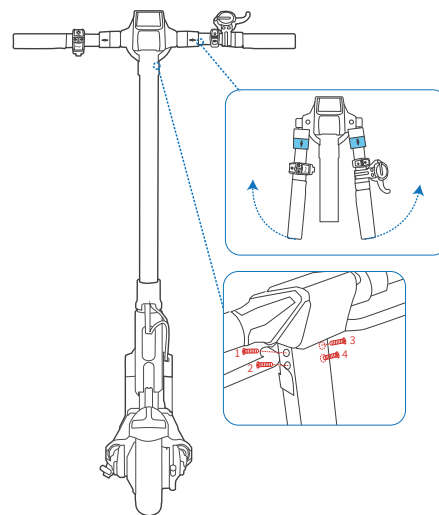

② Move the locking slide of handlebar outward and raise the handles.
③ Attach the folding handlebar body and tighten the 4 screws.
(When tightening the screw, the first step screw is 90% tight, according to the order 1-3-2-4; the second step all screws are 100% tightened.)



Bluetooth Connection

APP Download Guide

Method 1

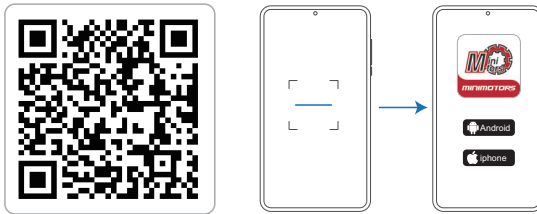

1. Scan the QR code to download the APP.
2. Choose the mobile phone system that suits you to install, and register / log in.

Method 2

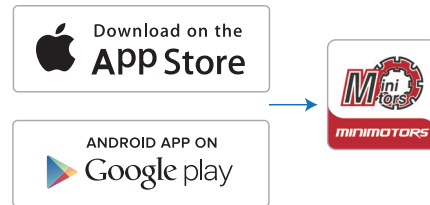

1. Search "DUALTRON" in the application and download it, and register / log in.

Pair the Bluetooth on the APP

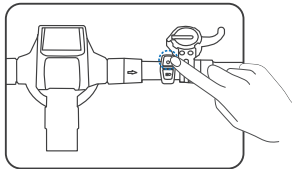

Power on the scooter.

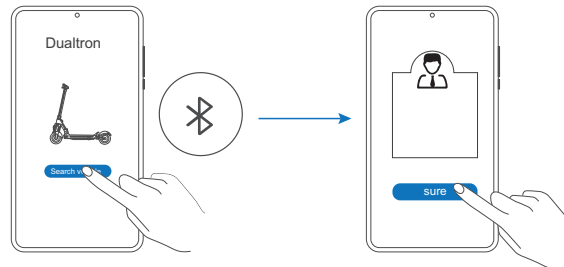

Click "Search vehicle" and pair with your scooter. * The scooter is connected to the Dualtron app when the Bluetooth symbol lights up.

Select "bind as owner".
(No one else can connect, only people authorized by you are allowed to connect. Authorizations are created on the app.)



How to Ride

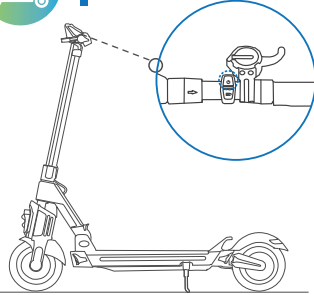

1. Power on the scooter and choose the speed mode. * Please choose the speed mode before riding! Note: Speed mode can be choose via the Dualtron app.



2. Stand on the footboard with one foot and push off with the other foot to start gliding. * Make sure you have disabled SAFE mode. (SAFE mode setting via Dualtron app. Deactivate safe mode by squeezing brake lever.)

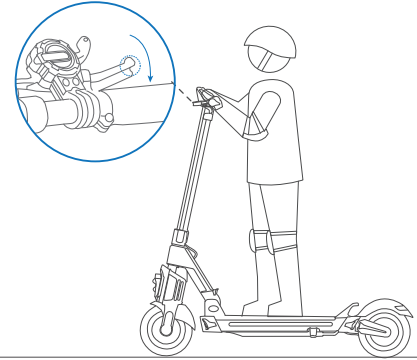

3. Put both feet on the footboard and stand stably. Pull the throttle to speed up. * This scooter starts at an initial speed of 0 km/h. Note: Disable the Zero start-up feature via the Dualtron app. When disabled, the motor will not engage until the scooter reaches 1.9 mph (3 km/h).

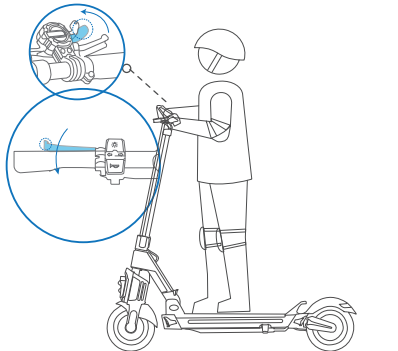

4. Slow down by releasing the throttle and squeezing brake levers.

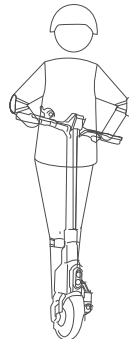

5. To turn, shift your body and turn the handlebar slightly. * Please watch out for road conditions, sufficient turning space is required.

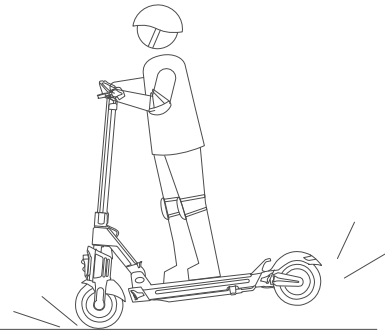

When hard braking, serious danger or injury may occur. Maintain a moderate speed and look out for potential hazards.



Folding

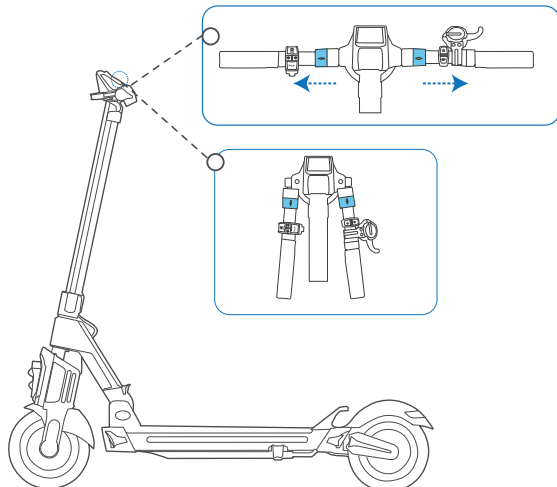

Move the locking slide outward and fold the handles.

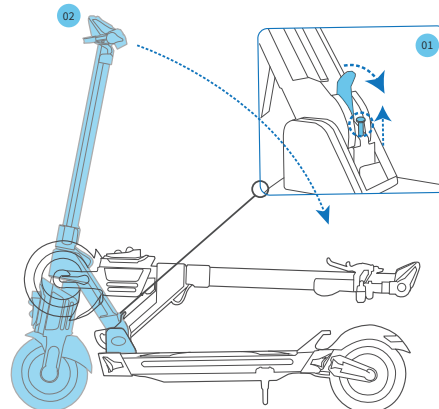

01. Pull the index pin upward and folding handle outward.

02. Hold the steering tube and slowly put it down until there is a click, and folding locked.

MEMO